

## Hammer Mill

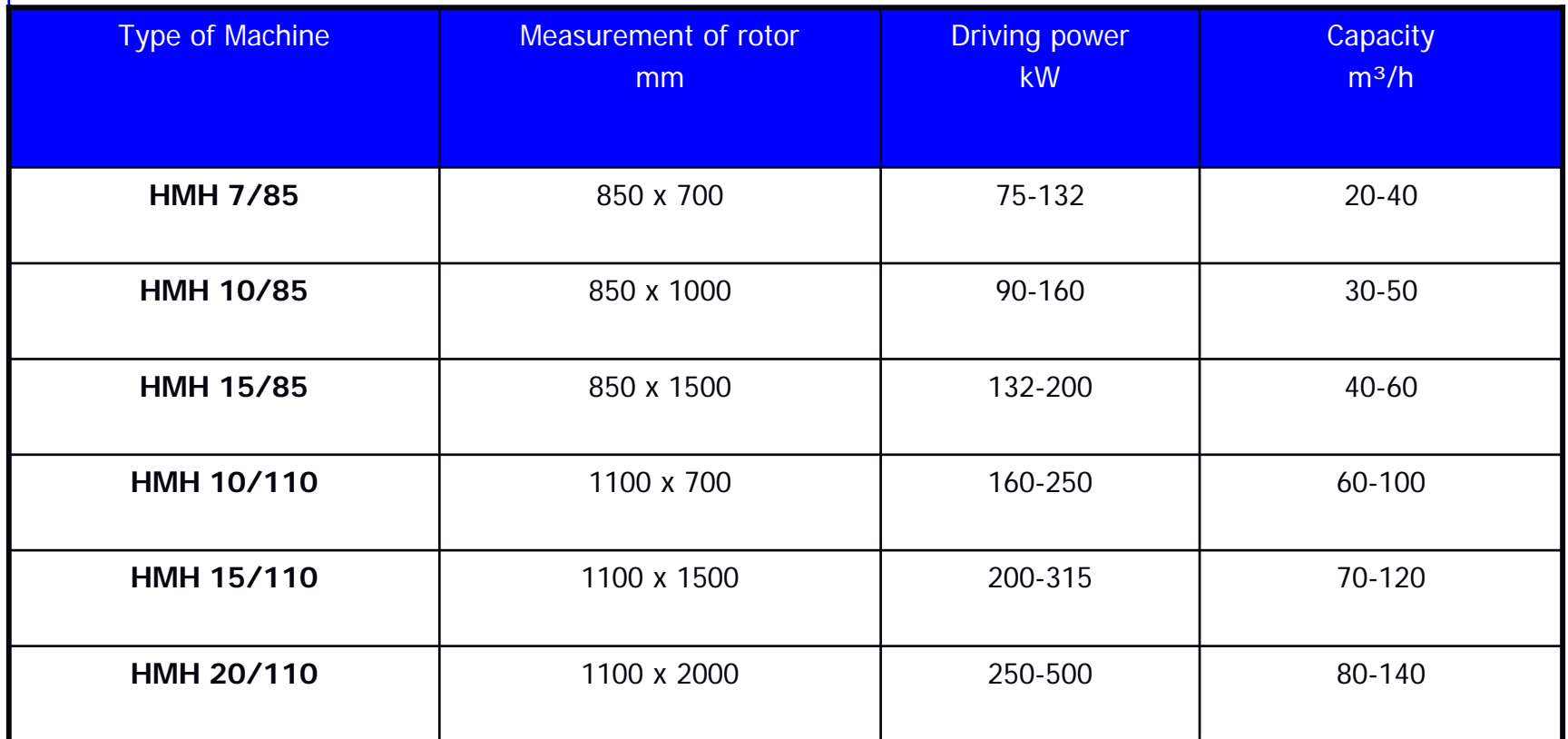

# Hammer Mill – Machine versions



Type of Machine	Measurement of rotor mm	Driving power kW	Capacity m <sup>3</sup> /h
<b>HMH 7/85</b>	850 x 700	75-132	20-40
<b>HMH 10/85</b>	850 x 1000	90-160	30-50
<b>HMH 15/85</b>	850 x 1500	132-200	40-60
<b>HMH 10/110</b>	1100 x 700	160-250	60-100
<b>HMH 15/110</b>	1100 x 1500	200-315	70-120
<b>HMH 20/110</b>	1100 x 2000	250-500	80-140

# Hammer Mill – Front view



Without cover

Drive of rotor  
with flat belt

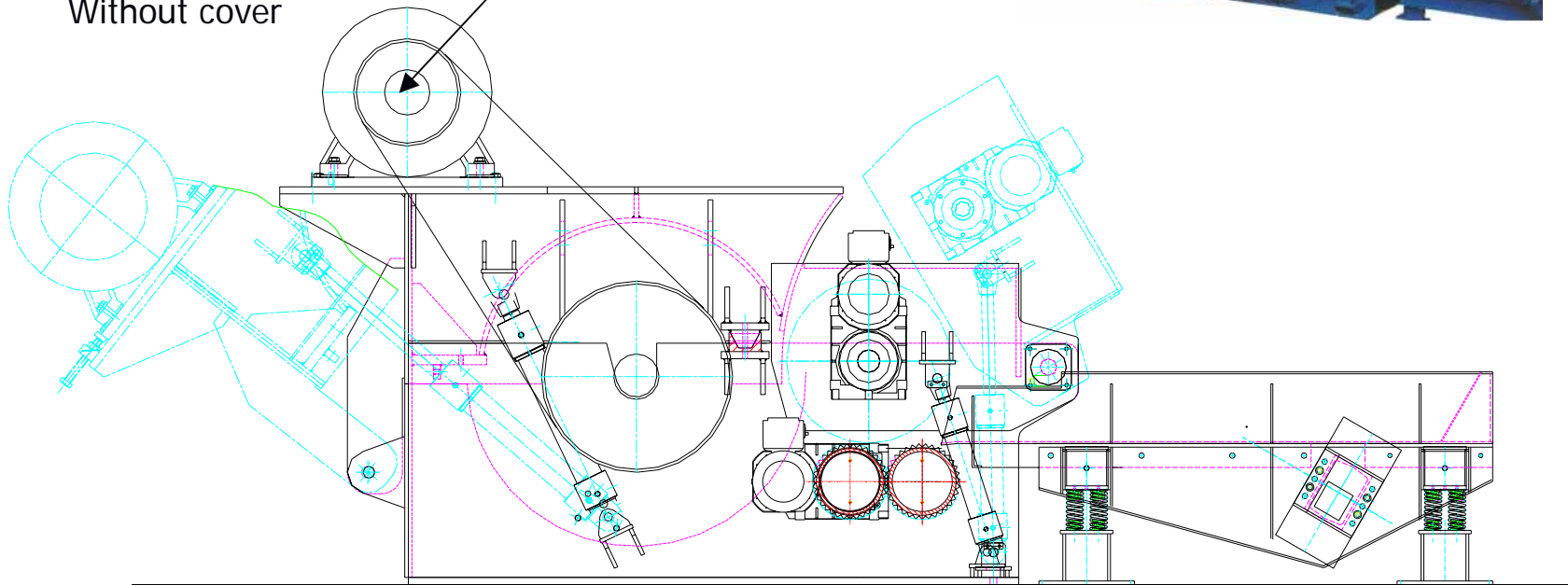

# Hammer Mill – Top View

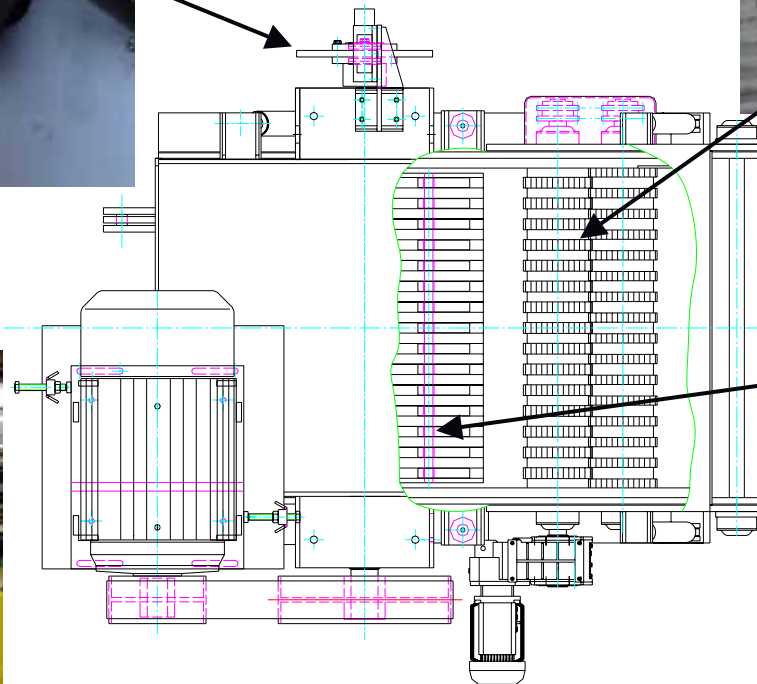
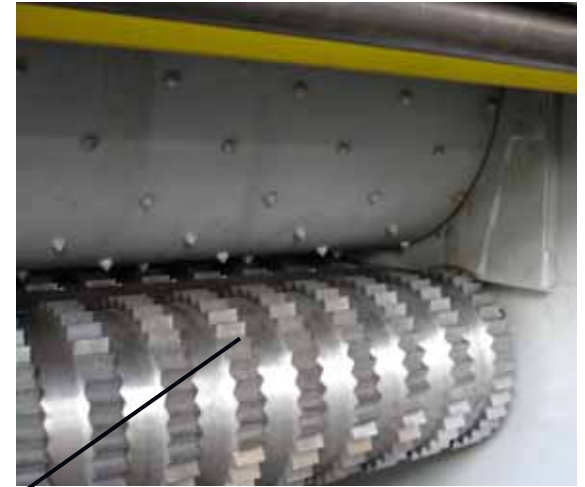

# Hammer Mill – Rotor

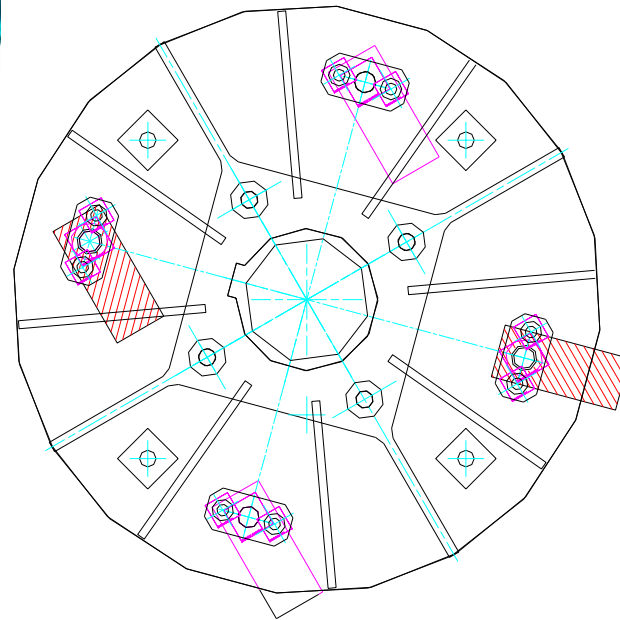
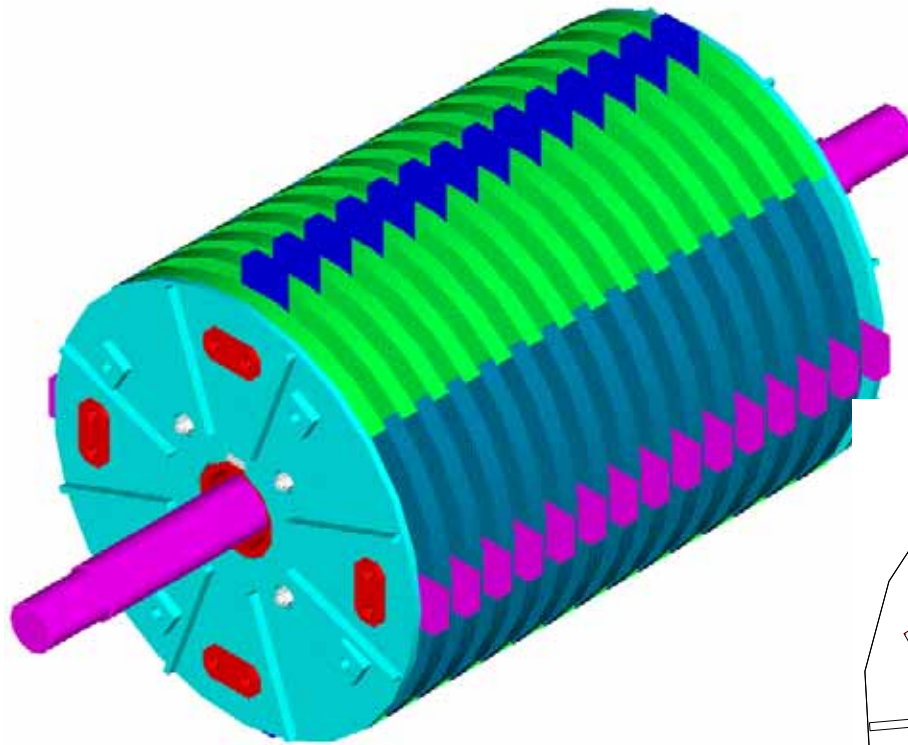

## Hammer Mill – Feeding material

chipboard



cardboard



wood



plastics



waste



## Hammer Mill – Screening segments

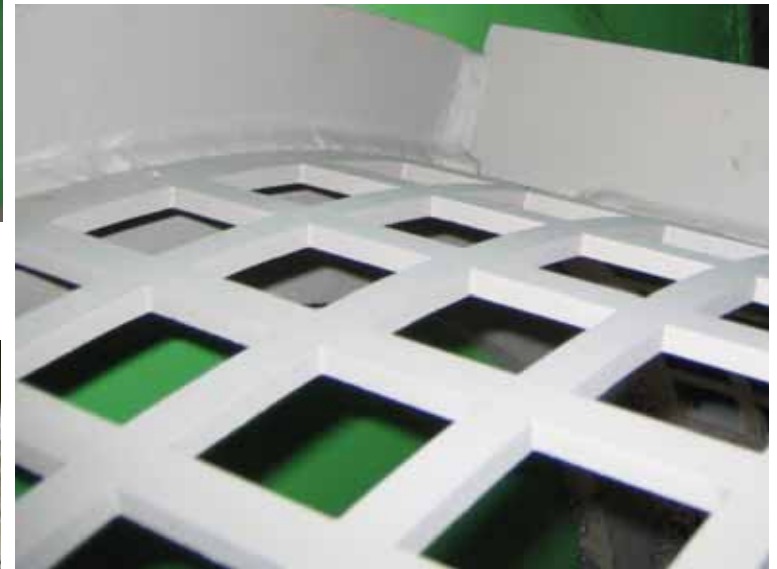
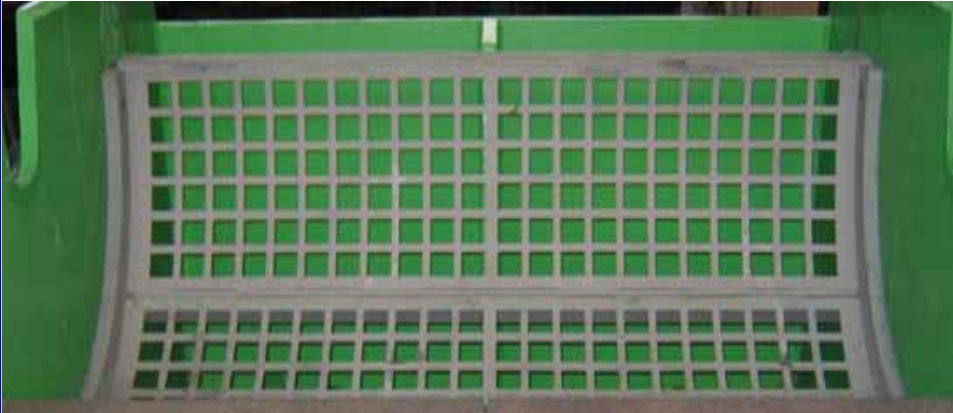

Counter steel and infeeding rolls

# Hammer Mill – Hammer



Special welding procedure for  
better performance



## Hammer Mill – During production

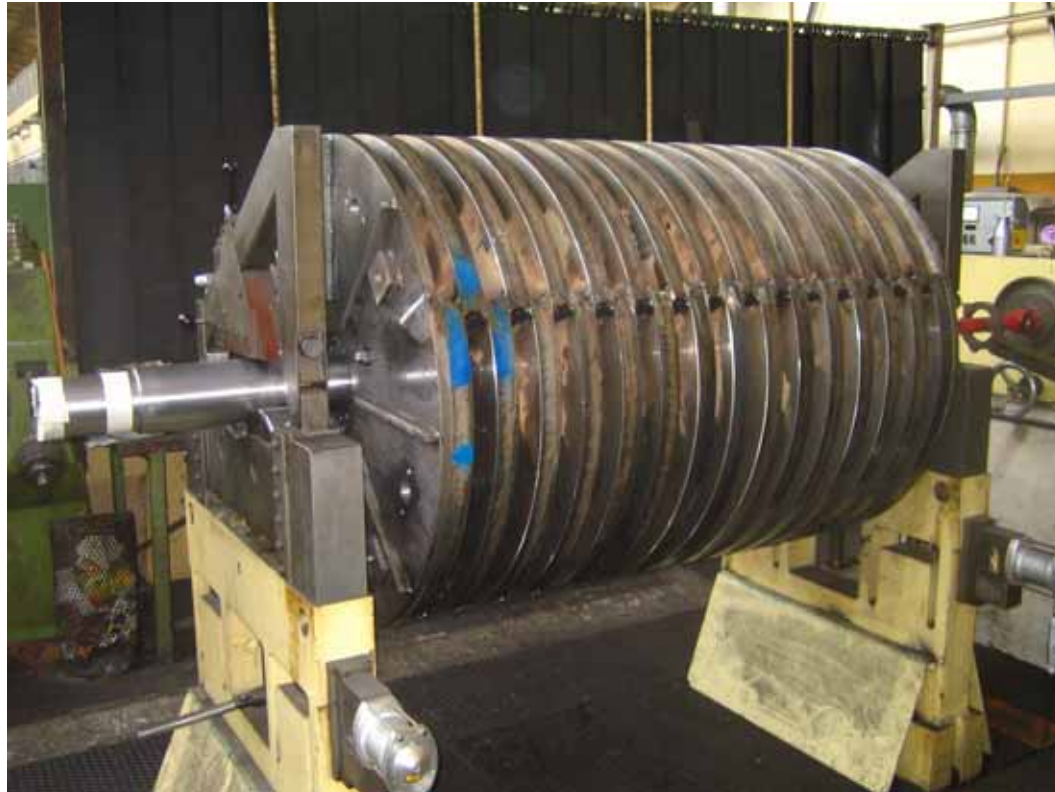

Shaft

## Hammer Mill – During production

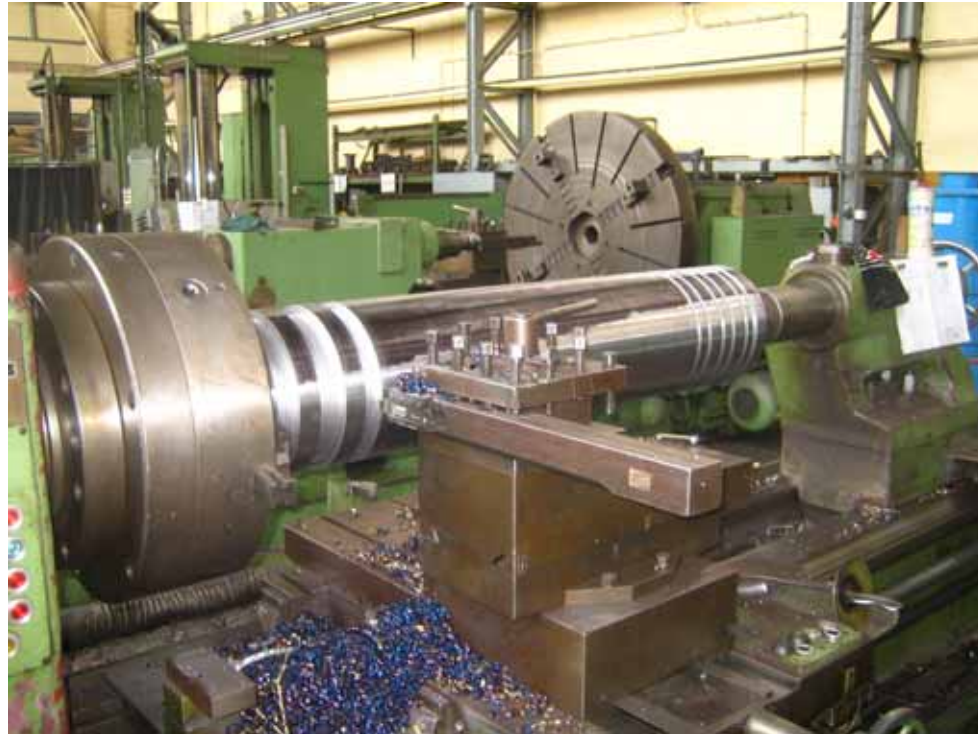

Grooving of the Infeed roll

## Hammer Mill – During production



Main frame

## Hammer Mill – Final machine



# Hammer Mill – 3D-Demonstration

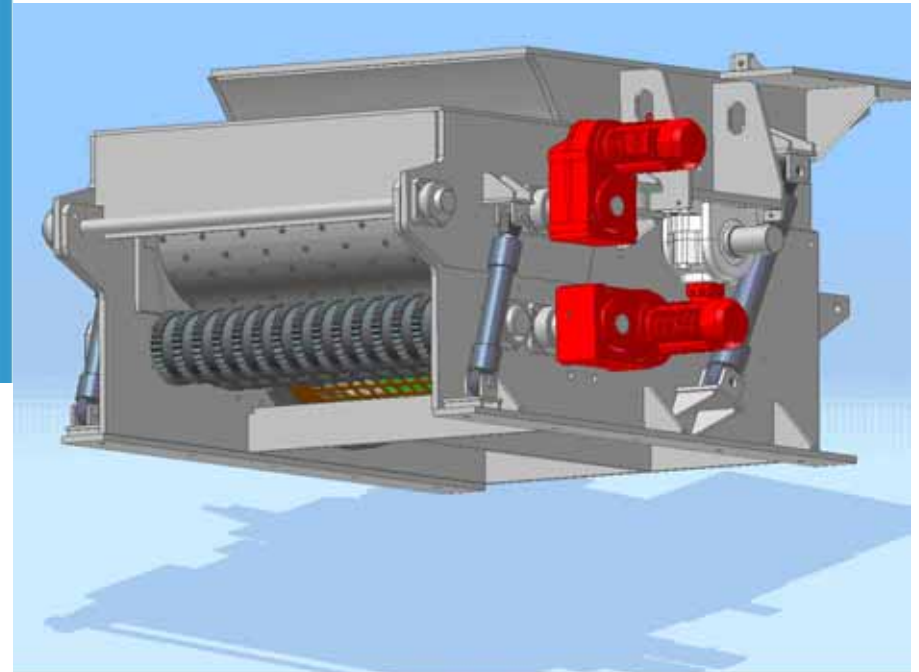
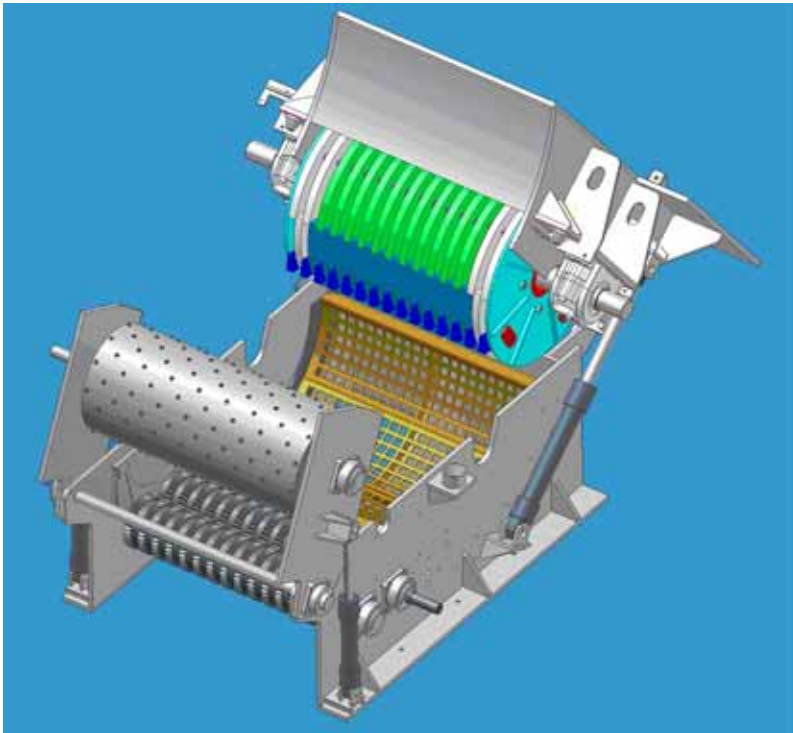

## Hammer Mill – Machine versions

In dependance of the feeding material HOMBAK may deliver three different hammer mill versions:

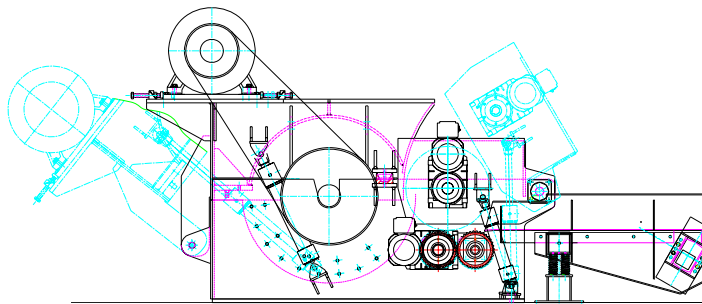

horizontal  
infeed

vertical  
infeed

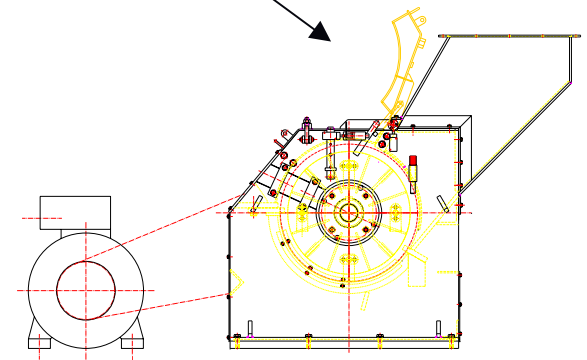
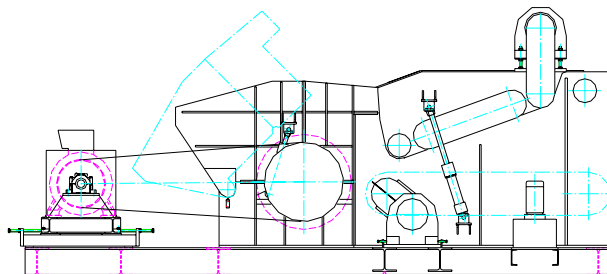

## Hammer Mill – Pre-Cutter

The infeed material will be first transported above the rotor

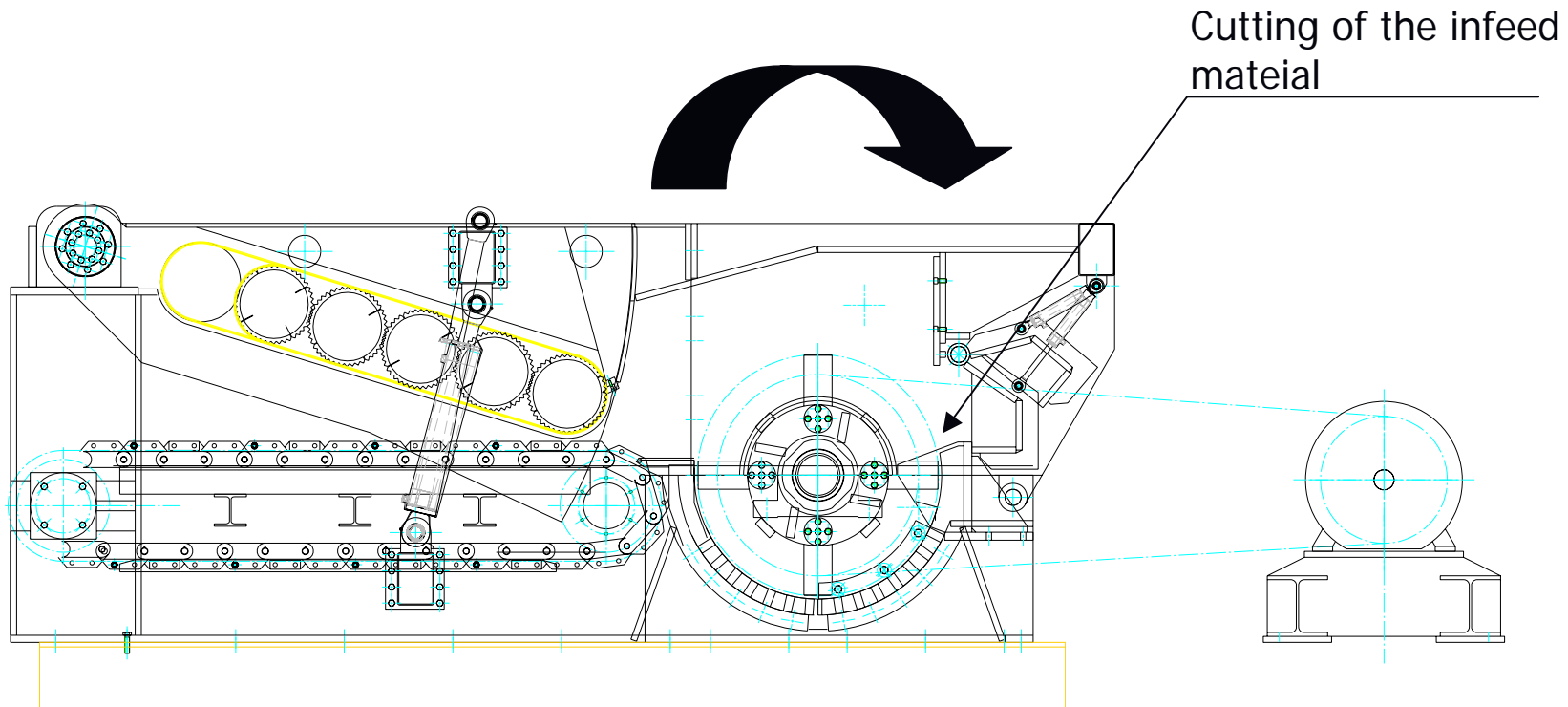

## Hammer Mill – Your advantages

- Horizontal or vertical, constant feeding over the vibrating conveyor
- High feed operation with upper roller
- Easy access for hydraulic maintenance and changing the hammers
- Quick change hammers and counter knives
- The hammers and screen are tailored to individual requirements
- Flat belt drive for better performance

## Contact

Maschinen- und Anlagenbau GmbH

Ph.: +49 (6 71) 7 07-0

Sandweg 2 – 6

P.O. Box 16 61

Fax: +49 (6 71) 7 07-67

E-Mail: [info@hombak.de](mailto:info@hombak.de)

D-55543 Bad Kreuznach

D-55506 Bad Kreuznach

Homepage: [www.hombak.de](http://www.hombak.de)